

# TQH 13

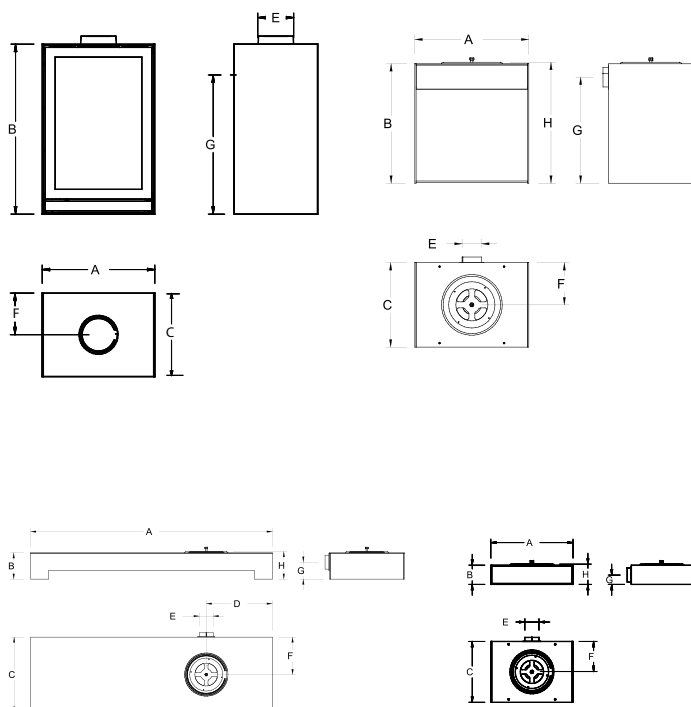

## FEATURES :

Built in steel
Woodbox® combustion technology
360° rotating main body
Vermiculite interior
Side loading door
Top and rear flue connection
Outside air ready
IR thermal self-cleaning ceramic glass
Ashpan
Primary and secondary air control
Optional remote control available
3 stand options; low-rise, tall log storage or steel bench

## STAND DIMENSIONS :

	A	B	C	D	E	F	G	H
Low rise	434	134	365	-	100	182	72	142
Log storage	434	425	365	-	100	182	358	433
Bench	1.700	186	528	465	100	264	120	194

## TECHNICAL SPECIFICATIONS :

Ecolabel	A+
Min.-max. heat output	2-8 kW
Nominal heat output	7,5 kW
Heats up to	260 m3
Side clearance to combustibles / non combustibles	150/50 mm.
Rear clearance to combustibles / non combustibles	150/75 mm.
Efficiency	85,1%
CO emissions	0,02%
Flue diameter	150 mm.
Maximum log length	550 vert. 330 hor.
Weight	173 kg.
Certification	EN 13240/16510
A	434
B	826
C	365
E	150
F	182,5
G	725