

# THS 15

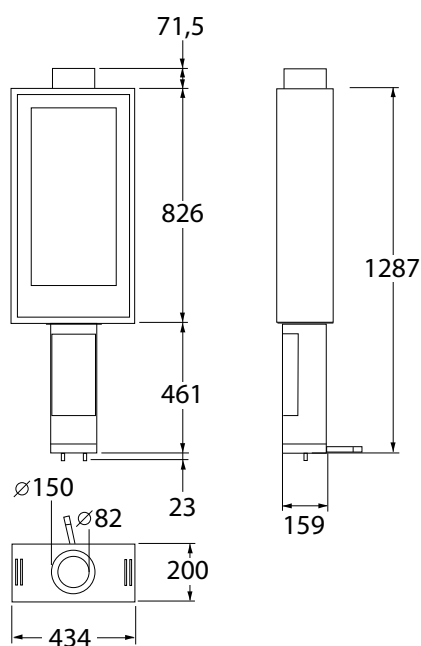

## FEATURES :

360° rotating body
Front an rear ceramic glass
Steel outer body
High efficiency burner technology
Ceramic log set
Remote and electronic flame control
Automatic ignition system
Field conversion kit for LP or NG
Top and rear flue exit
Long life cast iron heat baffle
Working door for easy maintenance
Optional rear protection pannel

## TECHNICAL SPECIFICATIONS (NG) :

Ecolabel	A
Min.-max. heat output	2,5-7,2kW
Nominal heat output	6 kW
Side clearance to combustibles / non combustibles	280/75 mm.
Rear clearance to combustibles / non combustibles	1.000 mm.
Efficiency	Class 1 (>84%)
Flue diameter	100 int. / 150 ext. mm.
Weight	87 kg.
Certification	EN 613