

# STANFORD 9

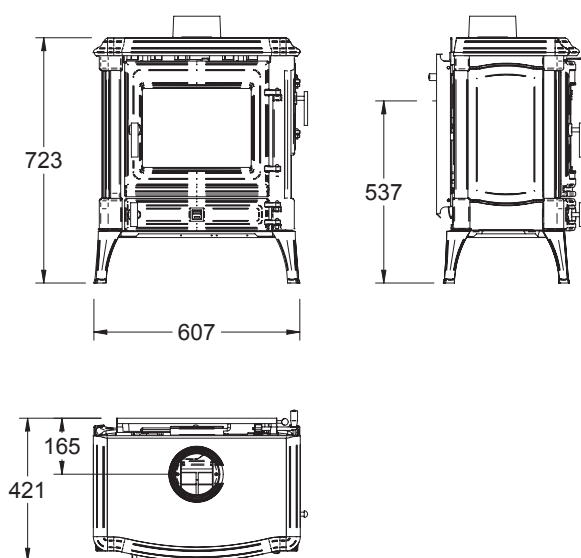

## FEATURES :

Built in cast iron
Heat-reflective cast iron interior
Multifuel combustion technology
Side loading door
Top or rear flue connection
Outside air ready
Self-cleaning ceramic glass
Ashpan
Thermostatic primary air control, manual secondary air control

## TECHNICAL SPECIFICATIONS :

Ecolabel	A
Min.-max. heat output	2-12 kW
Nominal heat output	8 kW
Heats up to	360 m3
Side clearance to combustibles / non combustibles	400/50 mm.
Rear clearance to combustibles / non combustibles	400/75 mm.
Efficiency	76%
CO emissions	0,06%
Flue diameter	125 mm
Maximum log length	400 mm
Weight	170 kg.
Certification	EN 13240/16510