

STANFORD 12+

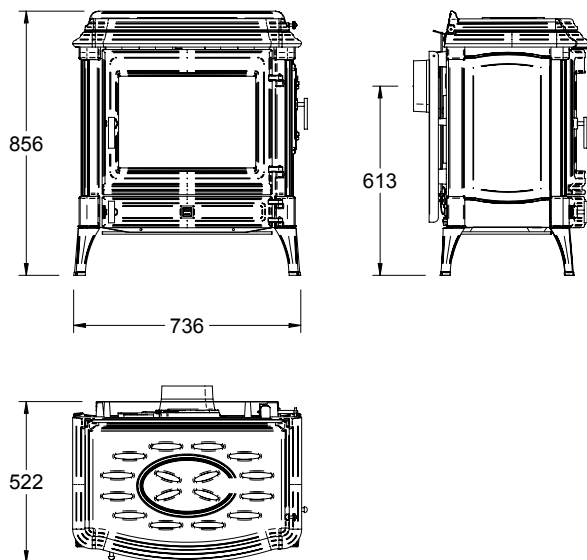

FEATURES :

Built in cast iron
Polished cast iron cooking plate with cast iron cover
Heat-reflective cast iron interior
Multifuel combustion technology
Side loading door
Rear flue connection
Outside air ready
Self-cleaning ceramic glass
Ashpan
Thermostatic primary air control, manual secondary air control

TECHNICAL SPECIFICATIONS :

Ecolabel	A
Min.-max. heat output	3-14 kW
Nominal heat output	12 kW
Heats up to	420 m ³
Side clearance to combustibles / non combustibles	400/50 mm.
Rear clearance to combustibles / non combustibles	400/75 mm.
Efficiency	76%
CO emissions	0,09%
Flue diameter	150 int. / 180 ext. mm
Maximum log length	500 mm.
Weight	200 kg.
Certification	EN 13240/16510