

STANFORD 12

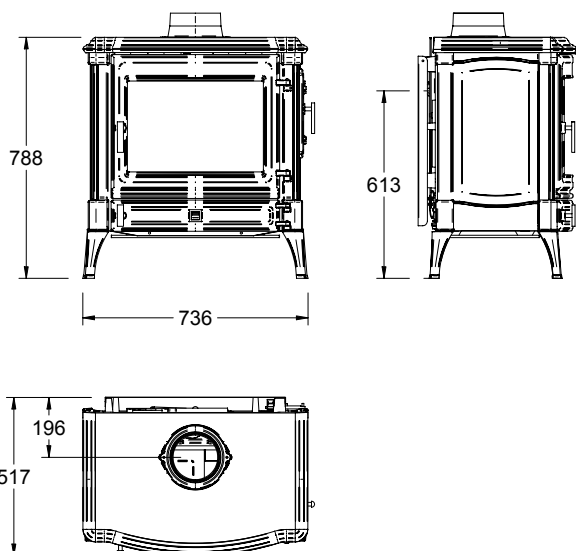

FEATURES :

| |
|--|
| Built in cast iron |
| Heat-reflective cast iron interior |
| Multifuel combustion technology |
| Side loading door |
| Top or rear flue connection |
| Outside air ready |
| Self-cleaning ceramic glass |
| Ashpan |
| Thermostatic primary air control, manual secondary air control |

TECHNICAL SPECIFICATIONS :

| | |
|--|------------------------|
| Ecolabel | A |
| Min.-max. heat output | 3-14 kW |
| Nominal heat output | 12 kW |
| Heats up to | 420 m ³ |
| Side clearance to combustibles / non combustibles | 400/50 mm. |
| Rear clearance to combustibles / non combustibles | 400/75 mm. |
| Efficiency | 76% |
| CO emissions | 0,09% |
| Flue diameter | 150 int. / 180 ext. mm |
| Maximum log length | 500 mm. |
| Weight | 200 kg. |
| Certification | EN 13240/16510 |