

# S 43

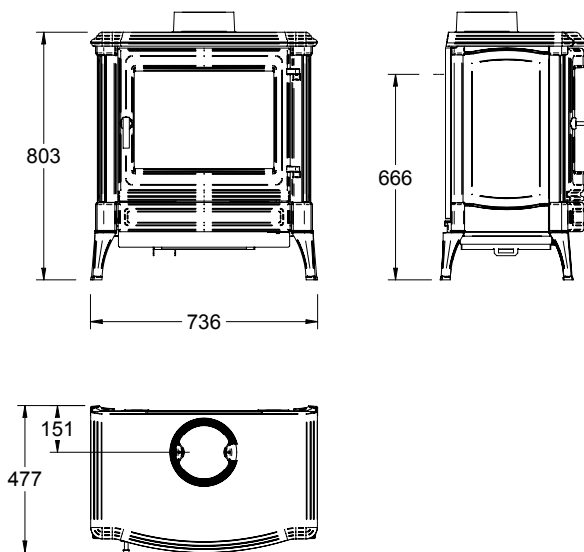

## FEATURES :

Built in cast iron
Woodbox® combustion technology
Heat-reflective cast iron interior
Multifuel combustion technology
Top and rear flue connection
Outside air ready
IR thermal self-cleaning ceramic glass
Ashpan
Primary and secondary air control
Optional remote control available

## TECHNICAL SPECIFICATIONS :

Ecolabel	A+
Min.-max. heat output	7-12 kW
Nominal heat output	9,5 kW
Heats up to	420 m <sup>3</sup>
Side clearance to combustibles / non combustibles	250/50 mm.
Rear clearance to combustibles / non combustibles	350/75 mm.
Efficiency	80%
CO emissions (13%O <sup>2</sup> )	1.341 mg/Nm <sup>3</sup>
Flue diameter	150 mm.
Maximum log length	500 mm.
Weight	197 kg.
Certification	EN 13240/16510