

# S 31

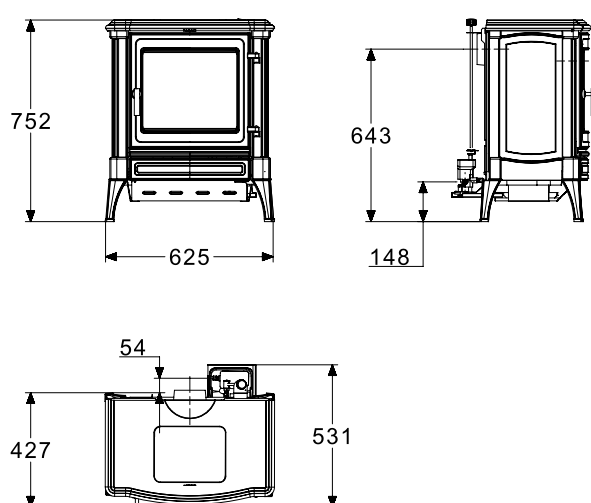

## FEATURES :

Cast iron outer body
Vaporizing burner technology
Electric or manual ignition
Easy flame height and heat output control
Easy connection to new or existing oil tanks
Non-pollutant, quiet and odor-free burning
Top and rear flue exit
Working door for easy maintenance

## TECHNICAL SPECIFICATIONS (NG) :

Ecolabel	E
Nominal heat output	8 kW
Side clearance to combustibles / non combustibles	300/50 mm.
Rear clearance to combustibles / non combustibles	300/75 mm.
Efficiency	81,2%
Flue diameter	100 int. / 125 ext. mm.
Minimum fuel consumption	0,26 l/h
Maximum fuel consumption	0,93 l/h
Weight	107 kg.