

# S 25

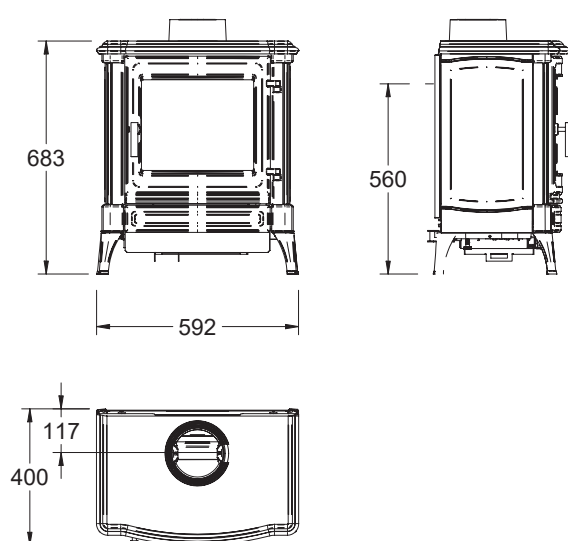

## FEATURES :

Cast iron outer body
High efficiency burner technology
Ceramic log set
Remote and electronic flame control
Automatic ignition system
Field conversion kit for LP or NG
Top and rear flue exit
Long life cast iron heat baffle
Working door for easy maintenance

## TECHNICAL SPECIFICATIONS (NG) :

Ecolabel	A
Min.-max. heat output	2,5-6,6 kW
Nominal heat output	6,7 kW
Side clearance to combustibles / non combustibles	280/75 mm.
Rear clearance to combustibles / non combustibles	280/75 mm.
Efficiency	Class 1 (>81,5%)
Flue diameter	100 int. / 150 ext. mm.
Weight	105 kg.
Certification	EN 613