

H 23

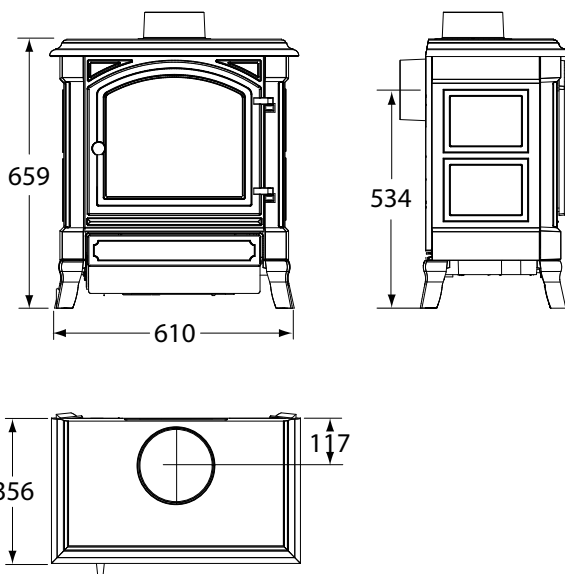

FEATURES :

Built in cast iron
Woodbox® combustion technology
Vermiculite interior
Multifuel combustion technology
Top and rear flue connection
Outside air ready
IR thermal self-cleaning ceramic glass
Ashpan
Primary and secondary air control
Optional remote control available

TECHNICAL SPECIFICATIONS :

Ecolabel	A
Min.-max. heat output	3-7 kW
Nominal heat output	4,5 kW
Heats up to	280 m ³
Side clearance to combustibles / non combustibles	250/50 mm.
Rear clearance to combustibles / non combustibles	200/75 mm.
Efficiency	79%
CO emissions (13%O ²)	1.000 mg/Nm ³
Flue diameter	150 mm.
Maximum log length	330 mm.
Weight	142 kg.
Certification	EN 13240/16510